

2nd Generation Intel® Core™ Processor 3U Single Board Computer



APPLICATIONS

The TP 86x/39x is a PC-compatible, high functionality, 3U CompactPCI® board supporting the 2nd generation Intel® Core™ processor and the Intel® Series 6 mobile class chipset all with up to 8 Gbytes of DDR3-1333 ECC SDRAM. This board can support a PMC/XMC site (or onboard 2.5-inch SATA drive) and features a variety of interfaces including three SATA channels, up to two CompactFlash® sites, up to three Gigabit Ethernet ports, two serial channels and four USB ports. The

TP 86x/39x is a commercial air-cooled board, suitable for a range of environments within industrial control, transportation, security, telemetry, scientific and medical applications. Options to operate in temperatures ranging from -40°C to +85°C are available. The board supports a build option to provide I/O plug compatibility with the popular TP 462/34x family. To simplify the board's integration many industry standard operating systems are supported.

HIGHLIGHTS

- 2nd generation Intel® Core™ processor:
 - 4-core 2.1 GHz Intel Core i7-2715QE processor
 - 2-core 1.5 GHz Intel Core i7-2610UE processor
 - 2-core 2.2 GHz Intel Core i7-2655LE processor
 - 2-core 2.5 GHz Intel Core i5-2515E processor
- Up to 8 Gbytes DDR3-1333 SDRAM with ECC
- Single/dual 3U CompactPCI slot configurations available
- PMC/XMC module interface, on optional second slot board with front and rear user I/O:
 - 32-bit, 33/66MHz PCI operation
 - XMC module interface (x4 PCI Express®)
- Up to 3 x 10/100/1000Mbps Ethernet interfaces
- 3 x SATA channels:
 - 2 channels accessed via J2
 - 1 channel used for SATA drive on optional second slot boards
- CompactFlash® site(s) on single and/or dual slot board:
 - optional second slot board provides either front loading or onboard CompactFlash
- 2 x serial channel interfaces
- Graphics interfaces, analog and optional digital
- 4 x USB 2.0 ports
- CompactPCI controller:
 - operates in the system slot or in a peripheral slot
 - PICMG® 2.1 R2.0 (Hot-Swap Specification)
 - 32-bit, 33/66 MHz CompactPCI interface
 - option to bypass CompactPCI bus (Satellite Mode)
- IPMI (Intelligent Platform Management Interface):
 - PICMG 2.9 (System Management Specification)
- Watchdog and long duration timer
- Extended temperature versions (E-Series, K-Series):
 - E: -25°C to +70°C, air-cooled
 - K: -40°C to +85°C, humidity sealant, air-cooled
- Support for Linux®, Windows® 7, Windows® Embedded Standard 7, Windows® XP, Windows® XP Embedded, Windows® Server 2008, QNX® and VxWorks®

Central Processor

- 4-core 2.1 GHz Intel® Core™ i7-2715QE processor
- 2-core 1.5 GHz Intel® Core™ i7-2610UE processor, 2.2 GHz Intel® Core™ i7-2655LE processor or 2.5 GHz Intel® Core™ i5-2515E processor
- common processor features are:-
 - 1333 MHz memory bus
 - Intel 64 technology (64-bit computing)
- shared Last-Level on-die cache:
 - 2.1 GHz Intel Core i7-2715QE - 6 Mbytes
 - 1.5 GHz Intel Core i7-2610UE - 4 Mbytes
 - 2.2 GHz Intel Core i7-2655LE - 4 Mbytes
 - 2.5 GHz Intel Core i5-2515E - 3 Mbytes
- utilizes Intel® Series 6 mobile class chipset:-
 - Intel® QM67 Platform Controller Hub (PCH)

SDRAM

- supports up to 8 Gbytes DDR3-1333 ECC SDRAM:-
 - up to 8 Gbytes soldered
 - peak bandwidth of 20 Gbytes/s
 - dual channel architecture
- accessible from processor or CompactPCI® bus

Optional Second Slot Boards

- second slot board, two options (see diagram)
- option 1 supports onboard:-
 - PMC/XMC site or 2.5-inch SATA disk drive
 - CompactFlash® site
- option 2 supports onboard:-
 - SATA disk drive (or external disk drive)
 - CompactFlash site, accessible via front panel (this site cannot be hot-swapped)

PMC/XMC Interface

- single PMC/XMC site available on an optional second slot board (option 1 in diagram):-
 - 32-bit, 33/66 MHz PCI operation
 - 3.3V and 5V PCI signaling levels
 - XMC interface supported via x4 PCI Express port
 - I/O via front panel, 64 bits via second slot J2

Mass Storage Interfaces

- 3 x SATA interfaces:-
 - 2 x SATA channels accessible via J2
 - 1 x SATA channel routed to 2.5-inch SATA drive on both types of optional second slot board (uses PMC/XMC site on option 1)
- 2 x SATA to EIDE interfaces:-
 - 1 x SATA channel routed to an on-board CompactFlash® site on the single slot board
 - 1 x SATA channel routed to a CompactFlash site on both second slot board options

Ethernet Interfaces

- up to 3 x 10/100/1000Mbps Ethernet interfaces
- 2 x Ethernet interfaces implemented by an Intel® 82580DB, via x4 PCI Express® port:-
 - 10 Base-T, 100 Base-TX, 1000 Base-T
 - first interface via front panel RJ45
 - second interface via J2 (no onboard magnetics) or switched to optional RJ45 on front panel
 - wake on LAN on both channels
- build option for 1 x Ethernet interface using the Ethernet controller within the PCH, via external Intel 82579 PHY (no onboard magnetics):-
 - 10 Base-T, 100 Base-TX, 1000 Base-T via J2

Graphics Interfaces

- implemented by Intel chipset
- VGA via a 15-way connector on front panel:-
 - up to 2048 x 1536 @ 75Hz, 32-bit color
- build option for DisplayPort via J2 connector:-
 - up to 2560x1600 @ 60Hz
- support for Microsoft® DirectX 10
- support for OpenGL 2.0, Windows and Linux

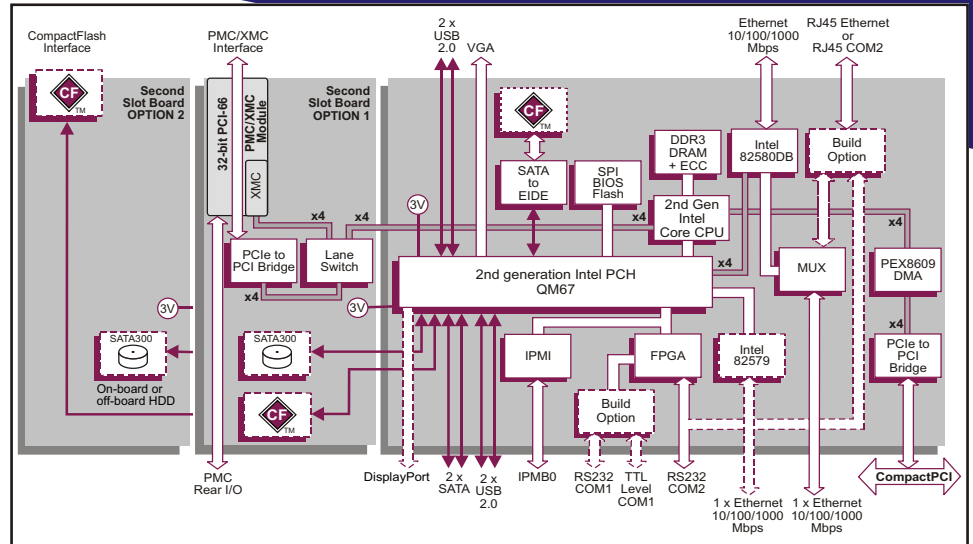

Serial Interfaces

- 2 x serial channels
- COM1 accessed via J2:-
 - build option for RS-232/422/485 on the AD TP1/006 Rear Transition Module (RTM)
 - or build option for RS232 transceivers (uses the AD TP1/008 RTM)
 - supporting RI, CTS, RTS, DSR, DTR and DCD
- COM2 accessed via J2 and via a RJ45 build option on the front panel :-
 - RS232 line level
 - supporting CTS, RTS, DSR, DTR and DCD via J2 and front panel, RI also via J2
- 16550 compatible UARTs

Other Peripheral Interfaces

- power management signals via J2:-
 - output: sleep status
 - inputs: power button, +5V standby voltage
- PC Real Time Clock
- long duration timer; watchdog timer
- 4 x USB 2.0 ports:-
 - 2 x USB ports accessed via J2
 - 2 x USB ports accessed via front panel
- 3 x GPO and 5 x GPI signals via J2
- legacy speaker interface

CompactPCI Interface

- universal signaling support, compliant with PICMG® 2.0 R3.0; 3.3V or 5V signaling levels
- 33/66 MHz; 32-bit interface accessed via J1:-
 - includes support for DMA
- operates as a System Slot controller (supporting up to 7 peripheral slots) or operates in a Peripheral Slot
- PICMG 2.1 R2.0 Hot Swap Compliant
- option to disable CompactPCI interface (Satellite Mode):-
 - receives power from CompactPCI bus
 - board can be hot swapped

IPMI

- PICMG 2.9 R1.0 (System Management Specification):-
 - implements the IPMB0 interface
- on-board Baseboard Management Controller
- monitors CPU temperature and voltages
- supports 8 Kbytes of non-volatile memory

Software Support

- supports Linux®, Windows® 7, Windows® Embedded Standard 7, Windows® XP, Windows® XP Embedded, Windows® Server 2008, QNX® and VxWorks®

SPI Flash EPROM

- 8 Mbytes of BIOS SPI Flash EPROM

Firmware Support

- Insyde Software InsydeH20™ BIOS:-
 - includes Compatibility Support Module
- based upon Intel® Platform Innovation Framework for EFI
- comprehensive Power-On Self-Test (POST)
- LAN boot firmware included

Electrical Specification (Estimated)

- typical current figures with 2.2 GHz Intel Core i7-2655LE, 4 GBytes DRAM:-
 - +5V @ 5A
 - +3.3V @ 4A
- +5V and +3.3V voltages are tolerant to +5%/-3%
- +12V and -12V not required

Safety

- PCB (PWB) manufactured with flammability rating of 94V-0

Environmental Specification

- operating temperatures:-
 - 0°C to +55°C (N-Series)
 - -25°C to +70°C (E-Series: 2.2 GHz or 1.5 GHz)
 - -40°C to +85°C (K-Series: 1.5 GHz)
- storage temperature: -40°C to +85°C
- 5% to 95% Relative Humidity, non condensing (operating or storage):-
 - K-Series includes humidity sealant

Mechanical Specification

- 3U form-factor:
 - 3.9 inches x 6.3 inches (100mm x 160mm)
- single or dual slot
- connectors: IEC-1076-4-101 for J1-J2
- operating shock: 20g, 11ms, 1/2 sine
- operating vibration:
 - 5Hz-2000Hz at 2g, 0.38mm peak displacement

I/O Compatible with the TP 462/34x

- build option provides rear I/O compatibility with the popular TP 462/34x family

ORDERING INFORMATION

Order Number Product Description (Hardware)

For the order number suffix (yz) options please contact your local sales office:
where y = width and rear I/O options where z = SDRAM size, I/O options

TP 865/39x-yz 4-core Core i7 processor, 3U CompactPCI SBC
TP 863/39x-yz 2-core Core i7 or Core i5 processor, 3U CompactPCI SBC

y - 1-slot wide or 2-slots wide

z - up to 8 Gbytes, I/O build options

For accessories and extended temperature options please contact your local sales office.

All companies and product names are trademarks of their respective organizations.
Specification subject to change; E and OE. RoHS 2002/95/EC compliant.

Datasheet Code 1649/0311
© Concurrent Technologies 2011