

NAMC-QorIQ-P5020

NAMC-QorIQ-P4080

NAMC-QorIQ-P3041

PACKET PROCESSOR AMC BOARD

DESIGNED BY N.A.T. GMBH



The **NAMC-QorIQ-Pxxx** is the market's most powerful single-width mid- or full-size AMC processor board designed around the high-performance NXP/Freescale PowerPC cores QorIQ P3041, P4080, and P5020, which are designed for packet oriented telecom applications such as LTE or VoIP.

The best of two worlds

The powerful QorIQ processor in combination with the Lattice ECP3-FPGA architecture results in an unrivalled power engine for data and packet processing as well as protocol acceleration. Providing I-TDM support by default, a major part of the FPGA is available for customer use.

IP-Cores are available for

- iTDM-Support
- IEEE1588/RTP timestamp insertion / synchronization
- PTP protocol acceleration

Real time clock/PLL

The **NAMC-QorIQ-Pxxx** can be equipped with an on-board Real Time Clock and precision oscillator to support time keeping and time tracking for protocols like RTP (Real Time Protocol) or PTP (Precision Time Protocol, IEEE 1588).

The low jitter PLL allows telecom clocks to be derived from on-board sources and to be provided to the system by the MTCA clock distribution network.

Applications

Due to the unique combination of the powerful and feature-rich packet processor and the Lattice ECP3-FPGA, the **NAMC-QorIQ-Pxxx** is ideally suited to any voice/data application with requirements like deep packet inspection, encryption, protocol conversion, or Layer 2-7 routing.

The **NAMC-QorIQ-Pxxx** is the optimal choice for applications like multi-service switches, edge routers, radio network controllers (RNCs), VoIP/VoP gateways, and routers as well as mobile network equipment.



KEY FACTS

	NAMC-QorIQ-P5020	NAMC-QorIQ-P4080	NAMC-QorIQ-P3041
Form Factor			
	<ul style="list-style-type: none"> • Single-wide, mid- or full-size AMC • Width: 73.5 mm, Depth: 180.6 mm 		
Processing Resources			
CPU	<ul style="list-style-type: none"> • NXP/Freescale QorIQ P5020 • 2x e5500 PowerPC Coress @ 2GHz 	<ul style="list-style-type: none"> • NXP/Freescale QorIQ P4080 • 8x e500mc PowerPC Cores @1.5GHz 	<ul style="list-style-type: none"> • NXP/Freescale QorIQ P3041 • 4x e500mc PowerPC Cores @ 1.5GHz
	<ul style="list-style-type: none"> • Security Engine • Pattern Match Engine • Queue and Buffer Managers 		
FPGA	<ul style="list-style-type: none"> • Lattice ECP3 Family 		
Memory	<ul style="list-style-type: none"> • Dual 64 bit Memory Interfaces 	<ul style="list-style-type: none"> • Dual 64 bit Memory Interfaces 	<ul style="list-style-type: none"> • Single 64 bit Memory Interfaces
	<ul style="list-style-type: none"> • 2x 1GB or 2x 2GB 64bit DDR3 RAM • 2x 1GB NAND FLASH • 1x 128MB NOR FLASH 		
Microcontroller	<ul style="list-style-type: none"> • Atmel ATmega128 as IPMI-Controller 		
Firmware			
	<ul style="list-style-type: none"> • OK1, QNX BSP and LINUX BSP (on request) 		
Backplane Interconnect			
	<ul style="list-style-type: none"> • Ports 0/1: Dual 1GbE connect 		
	<ul style="list-style-type: none"> • Ports 2/3: SATA 	<ul style="list-style-type: none"> • na 	<ul style="list-style-type: none"> • Ports 2/3: SATA
	<ul style="list-style-type: none"> • Ports 4-7/8-11: XAUI, SRIO, and PCIe 		
Front Panel			
	<ul style="list-style-type: none"> • na 	<ul style="list-style-type: none"> • Port 2/3: XAUI via SFP+ 	<ul style="list-style-type: none"> • na
	<ul style="list-style-type: none"> • Gigabit Ethernet via RJ45 • USB via USB Type A • RS232 via Mini-USB 		
LEDs			
	<ul style="list-style-type: none"> • Standard AMC LEDs for Hot-Swap-Status and System Health • Status LEDs for GbE 		
Compliance			
	<ul style="list-style-type: none"> • PICMG AMC.0 Rev. 2.0 • PICMG AMC.1 Rev. 1.0 • PICMG AMC.2 Rev. 1.0 (Type E2) • PCI Express Base Specification Rev. 1.1 • PICMG SFP.0 Rev. 1.0 (System Fabric Plane Format) • PICMG SFP.1 Rev. 1.0 (Internal TDM) • IPMI Specification v2.0 Rev. 1.0 • PICMG µTCA.0 Rev. 1.0 		
Environmental			
Operating Environment	<ul style="list-style-type: none"> • 0 to +55 degrees Celsius (with forced cooling) • Humidity: 10% to 90% (non-condensing) 		
Storage Environment	<ul style="list-style-type: none"> • -40 to +85 degrees Celsius • Humidity: 10% to 90% (non-condensing) 		



NAMC-QorIQ-Pxxx PACKET PROCESSOR AMC BOARD

DATASHEET V1.1

Figure 1 – NAMC-QorIQ-P5020

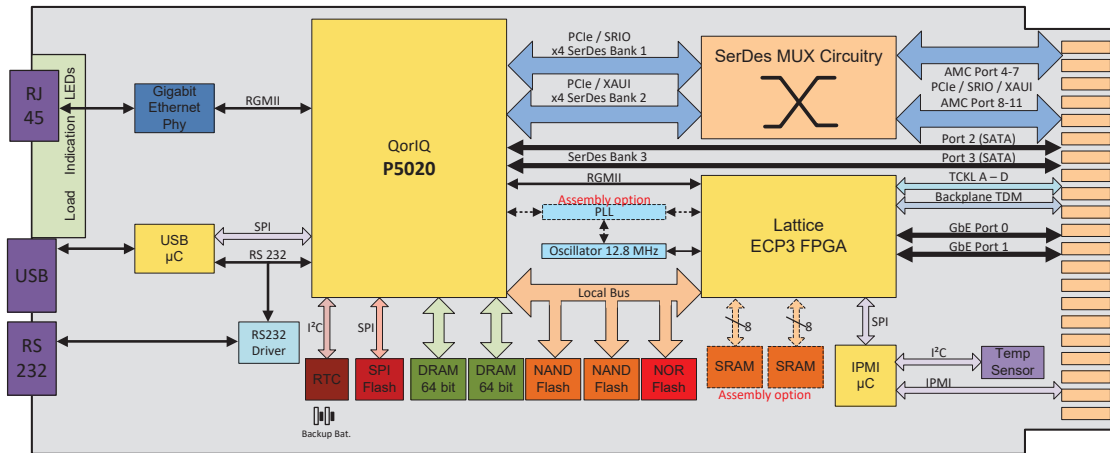

Figure 2 – NAMC-QorIQ-P4080

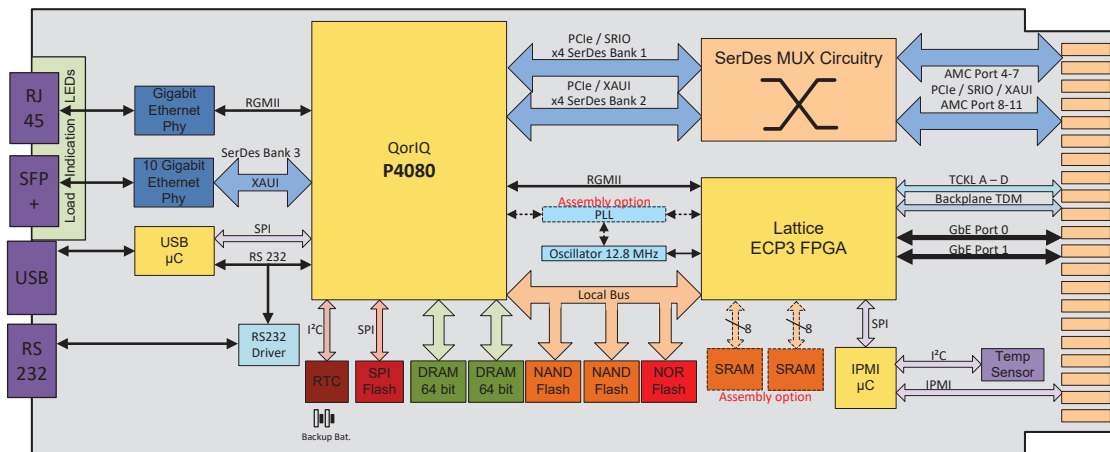

Figure 3 – NAMC-QorIQ-P3041

