

3U VPX SOSA Aligned Compute Intensive Plug In Card (PIC) based on Intel Xeon D-1800 Processor Family

Key Features

TR MDx/6sd is a compute intensive rugged Plug In Card. It has been developed in alignment with the SOSA™ Technical Standard. It features a processor with 10 cores, large memory capacity, local storage, and support for virtualization.

- Lightweight build and prime performance across thermal range
- 128 Gbytes DDR4 memory for server grade applications
- 40GBASE-KR4 or 100GBASE-KR4 Primary Ethernet Data plane
- Support for FIPS 140-3 1TB M.2 Storage Module

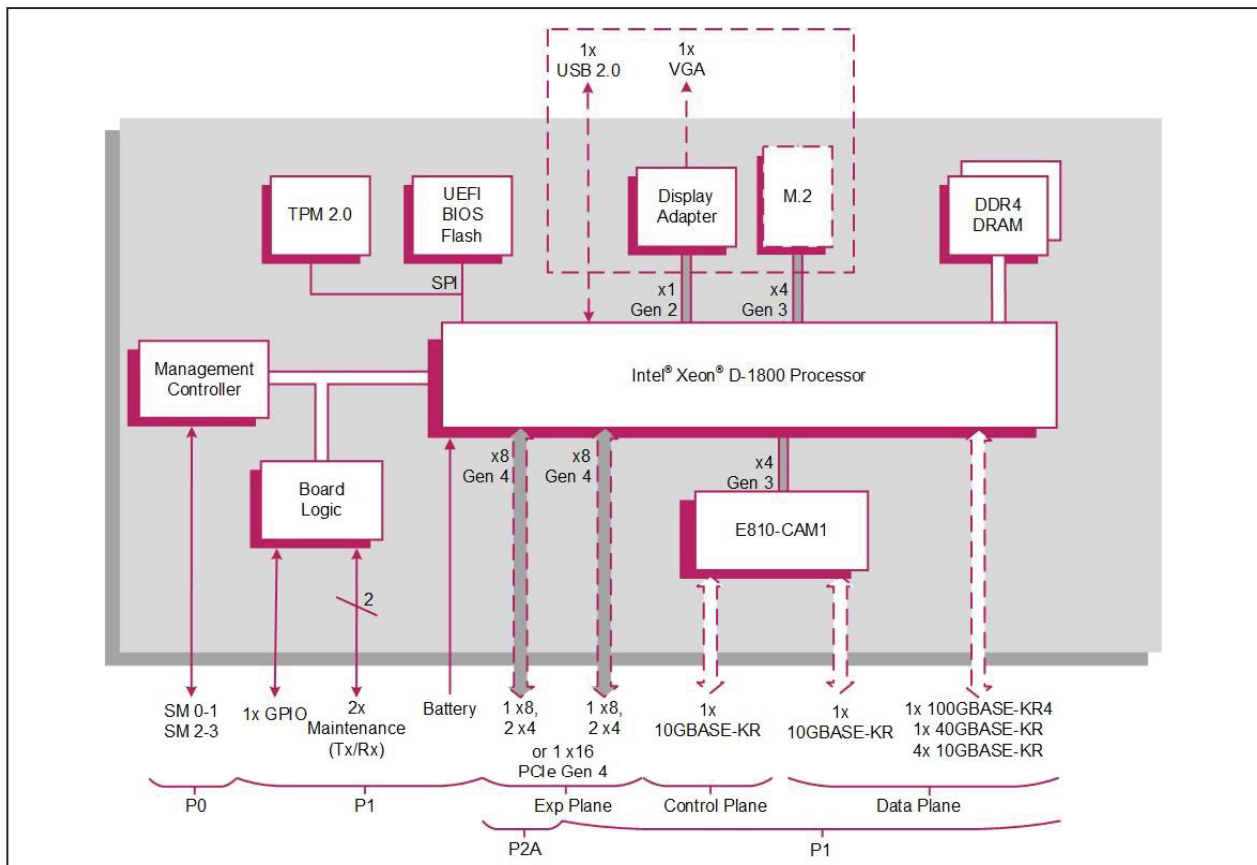

Specification

VPX Processor PIC

- rugged conduction-cooled 3U VPX computing PIC utilizing Intel Xeon D-1800 Processor
- compliant with two OpenVPX slot and module profiles:
 - SLT3-PAY-1F1U1S1S1U1U2F1H-14-6.11-0
 - MOD3-PAY-1F1U1S1S1U1U2F1H-16-6.11-4
 - SLT3-PAY-1F1U1S1S1U1U4F1J-14.6.13-n
 - MOD3-PAY-1F1U1S1S1U1U4F1J-16.6.13-1

Central Processor

- 10-core Intel Xeon D-1848TER Processor:
 - 15 Mbytes Cache, up to 2.0 GHz, up to 57 W
- Intel Advanced Vector Extensions AVX-512
- Intel Vector Neuro Network Instructions (VNNI)
- Intel Vector Byte Manipulation Instructions (VBMI)
- server class processing cores in a System-on-a-Chip package
- range of performance/power factory build options

DRAM

- 128 Gbytes soldered DDR4 ECC DRAM:
 - single bit error correction and dual bit error detection

Maintenance Serial Ports

- 2x maintenance ports via P1:
 - supports LVCMOS levels
 - supports RS232 Tx/Rx signals
 - 16550 compatible UARTs

Mass Storage Interfaces

- optional M.2 Carrier Module supporting:
 - 1x M.2 Flash site
 - 2242 format modules (with option for self-encryption)
 - x4 PCI Express (PCIe) interface (M-key)
 - FIPS 140-2 and Opal 2.0 security encryption
 - Write Protect
 - NVMe Express (NVMe) logical device interface
 - NVMe 1.3 compatible

Console Interface

- for board commissioning an optional on-board console interface is available via a forward facing 16-way I/O connector:
 - supported on the M.2 Carrier Module
 - VGA interface (up to 1920 x 1080 @ 60 Hz)
 - USB 2.0 port for user interface
 - separate adapter cable available with standard VGA and USB connectors

Other Peripheral Interfaces

- PC RTC, long duration timer, watchdog timer

VPX Data Plane, 40/100 Gigabit Ethernet (optional)

- configurable Ethernet VPX Data Plane fabric interface (VITA 46.7)
- VPX Primary Data Plane interface supports:
 - 1x 100GBASE-KR4 or 1x 40GBASE-KR4 or 4x 10GBASE-KR
- VPX Secondary Data Plane interface supports:
 - 1x 10GBASE-KR or 1x 25GBASE-KR
- factory build option available to disable Data Plane

VPX Control Plane, 10 Gigabit Ethernet (optional)

- configurable Control Plane (VITA 46.6)
- VPX Control Plane interface supports:
 - 1x 10GBASE-KR or 1x 25GBASE-KR
- factory build option available to disable Control Plane

VPX Expansion Plane, PCIe (optional)

- configurable PCI Express (PCIe) Gen 4 VPX Expansion Plane fabric interface (VITA 46.4):
 - 1 x16 on P1 and P2A PCIe ports
 - 1 x8 on P1 and/or 1 x8 on P2A PCIe ports
 - 2 x4 on P1 and/or 2 x4 on P2A PCIe ports
- factory build option available to disconnect Expansion Plane

System Management

- IPMC on-board controller:
 - SM0-1 and SM2-3
- VITA 46.11-2022 IPMC
- option for VITA 46.11-2022 compatible Tier 1 Chassis Manager

Board Security Features

- Trusted Platform Module (TPM 2.0)
- supports Total Memory Encryption
- option for Sanitization Utility Software Package
- option for proprietary board-level security features
- implements Intel Boot Guard and Intel SGX

Optional Built-In Test (BIT) Support

- Power-on BIT, Initiated BIT, Continuous BIT

Software Support

- supports Linux
- for other operating systems such as VxWorks, contact Concurrent Technologies for further information

Firmware Support

- single BIOS SPI Flash EPROMs
- UEFI boot firmware (BIOS):
 - UEFI 2.7 support
 - implements Secure Boot
- optional Fast Boot solution using the Intel Slim Bootloader
- LAN boot firmware included

Safety

- PCB (PWB) manufactured with flammability rating of UL94V-0

Electrical Specification

- typical current consumption for 10-core processor (2.0 GHz):
 - +12 V VS1 @ TBD
 - +3.3 V AUX @ TBD

Environmental Specification

- conduction-cooled (VITA 48.2)
- operating temperature at card edge:
 - VITA 47.1 Class CC3, -40 C to +70 C (RCx-Series)
 - VITA 47.1 Class CC4, -40 C to +85 C (RCx-Series) - Contact Concurrent Technologies for more details
- non-operating temperature:
 - VITA 47.1 Class C4, -55 C to +105 C
- operating altitude:
 - -1,500 to 60,000 feet (-460 to 18,300 meters)
- rapid decompression:
 - From 8,000 to 60,000 feet (from 2440 to 18,300 meters)
- 5% to 95% Relative Humidity, non-condensing

Mechanical Specification

- 3U VPX form-factor (VITA 46.0, VITA 48.0): 3.9-inches x 6.3-inches (100 mm x 160 mm)
- slot width (VITA 48.0):
 - 1.0-inch VPX-REDI Type 1, RCR-Series Type 1 Extended Covers Two Level Maintenance (VITA 48.2)
- connectors to VITA 46.0 for P0, P1 and P2A
- captive screws available to secure front handles
- operating mechanical:
 - shock - VITA 47.1 Class OS2, 40 g
 - random vibration - VITA 47.1 Class V3, 0.1 g /Hz