

## VME board based on Intel Atom Processor x7000 Series

### Key Features

Rhea (VP ECx/msd) is a low power consumption VME board with a wide spread of I/O interfaces that has been designed for long life-cycle applications.

- 4-core and 2-core processor (previously Amston Lake) options allowing for performance and power optimizations
- 16 Gbytes DRAM with in-band error correction for reliable operation
- Up to 2 x PMC/XMC module interfaces for local I/O expansion
- Built in I/O interfaces including SATA, USB, Ethernet, graphics, GPIO, audio and serial
- On board solid state disk option for reliable boot image and data storage
- Off the shelf board support packages available for Linux and Windows

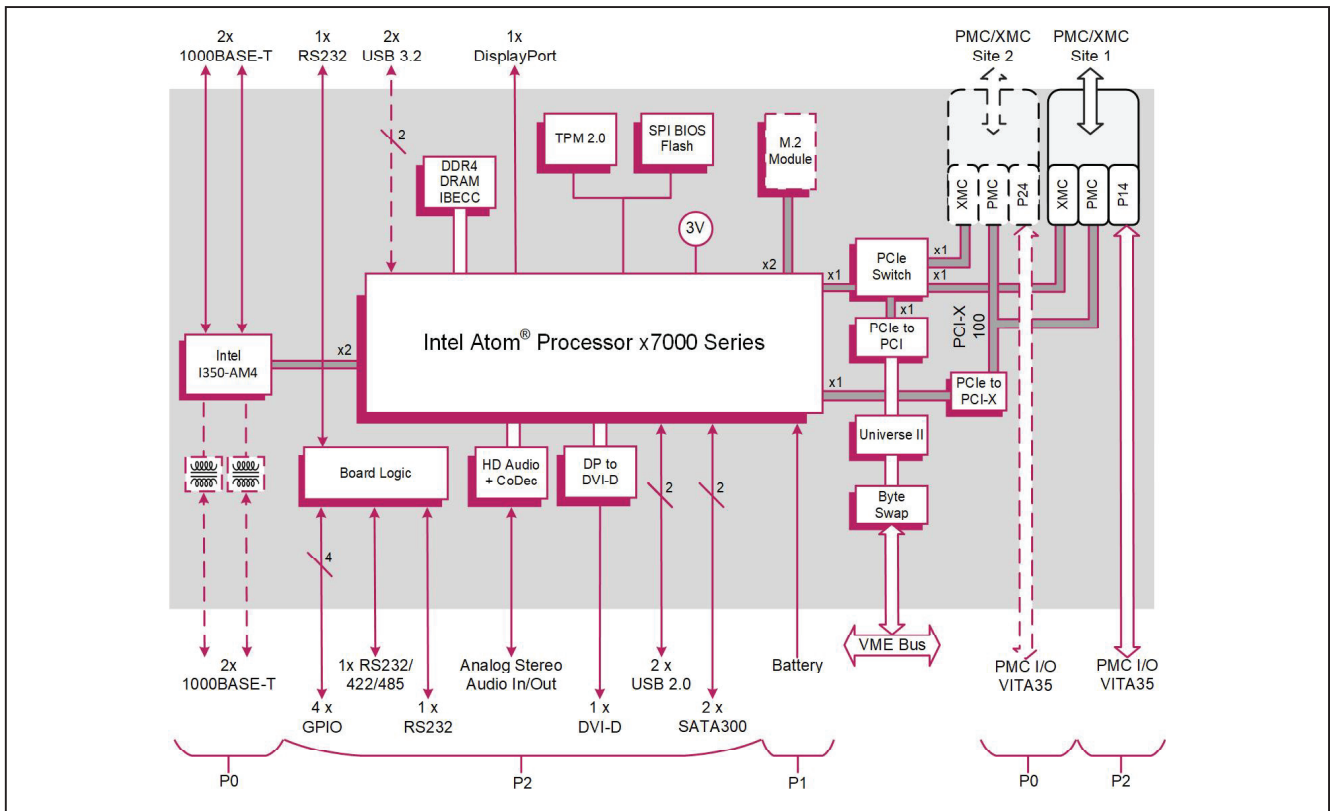
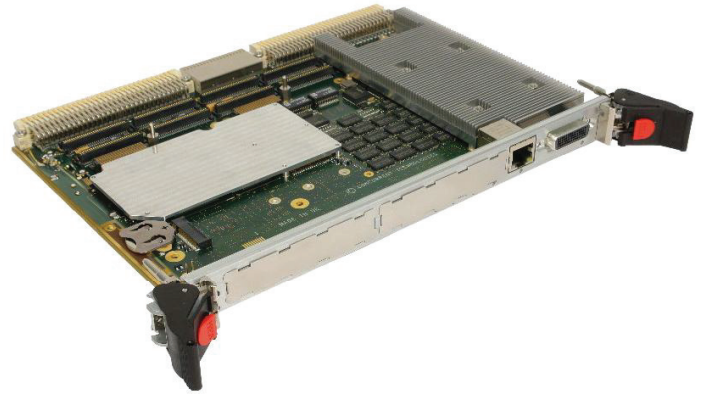

# Specification

## Central Processor

- Intel Atom processor x7000 Series:
  - 4-core 1.5Ghz Intel Atom processor x7433RE
  - 2-core 2Ghz Intel Atom processor x7213RE

## DRAM

- 16 Gbytes soldered DDR4 DRAM, in-band ECC:
  - 3200MT/s

## Mass Storage Interfaces

- Up to 2 x external SATA300 interfaces:
  - 2 x SATA via P2
- On-board PCIe support for optional:
  - M.2 Module

## Ethernet Interfaces

- Up to 4 x Gigabit Ethernet interfaces:
  - Implemented by an Intel I350-AM4 Ethernet Controller via a x1 PCI Express Gen 2 port
- 2 x Gigabit Ethernet interfaces via front panel RJ45 connectors
- 2 x Gigabit Ethernet interfaces via rear:
  - Via optional P0
  - One interface supports VITA 31.1 (Gigabit Ethernet for VME64x backplanes)
  - On-board magnetics (50V isolation via P0)

## PMC/XMC Interfaces

- Single or dual PMC/XMC interfaces
- PMC/XMC site 1:
  - Front panel I/O
  - P14 rear I/O via P2 (VITA 35)
- PMC/XMC site 2 (build option):
  - Front panel I/O: option for PMC/XMC site or extra front panel I/O connectors (USB 3.2 and DisplayPort interfaces)
  - P24 rear I/O via optional P0 (VITA 35)
- PMC interface(s) support:
  - Shared 32/64-bit, 33/66MHz PCI bus
  - Shared 64-bit PCI-X bus up to 100MHz
  - 5V and 3.3V signaling
- XMC (Switched Mezzanine Card) site(s):
  - Support x1 PCI Express (Gen 1, Gen 2, Gen 3)
  - Both powered from 5V supply
- Expansion to optional dual PMC/XMC carrier board via x1 PCI Express XMC site

## Serial Interfaces

- 1 x RS232 via RJ45 on front panel:
  - Tx, Rx, CTS, RTS, DSR, DTR and DCD
- 1 x RS232/422/485 via P2:
  - RS232 supports Tx, Rx, CTS, RTS, DSR, DTR, DCD and RI
- 1 x RS232 via P2 (build option):
  - Tx and Rx
- 16550 compatible UARTS

## Stereo Audio

- Intel High Definition Audio interface (on-board codec) via P2 (build option):
  - Analog stereo audio input and output

## Graphics Interfaces

- DisplayPort interface via front panel (single site build option, disables PMC/XMC site 2): Up to 1920 x 1080 @ 16M colors

## Other Peripheral Interfaces

- PC-compatible Real Time Clock
- Watchdog timer; 1 x 32-bit Long Duration Timer with processor interrupt capability
- Up to 4 x USB interfaces:
  - 2 x USB 3.2 on the front panel (single site option, disables PMC/XMC site 2)
  - 2 x USB 2.0 via P2 connector
- 4 x GPIO signals via P2 with processor interrupt capability

## Flash EPROM

- Dual BIOS SPI Flash EPROM

## Software Support

- Supports Linux and Windows

## Firmware Support

- AMI UEFI BIOS
- Optional Fast Boot solution based on the Intel Firmware Support Package (Intel FSP)
- LAN boot firmware included

## Optional Built-In Test (BIT) Support

- Power-on BIT (PBIT), Initiated BIT (IBIT), Continuous BIT (CBIT)

## Optional Board Security Features

- Trusted Platform Module (TPM):
  - TPM 2.0
- Option for Sanitization Utility Software Package
- Proprietary board-level security features

## VME Interface

- P1 and P2 connectors compatible with VME64x
- Implemented using IDT Universe II device
- VME Master/Slave
- A32/A24/A16/D64/D32/D16/D8(EO)/MBLT
- Fast hardware byte swapping
- Auto system controller detect
- Full interrupter / interrupt handler support
- Bus error interrupt hardware

## Safety

- PCB (PWB) manufactured with flammability rating of UL94V-0

## Electrical Specification

- Typical power consumption is typically TBD for the 2-core Intel Atom processor x7213RE board
- +5V (+5%/-2.5%) is required, +3.3V is not required
- +12V @ 0.0A; -12V @ 0.0A
- +12V and -12V routed to both PMC/XMC sites

## Environmental Specification

- Commercial operating temperature (N-Series):
  - 0 C to +70 C
- Extended operating temperatures (E-Series):
  - -25 C to +70 C
- Extended operating temperatures (K-Series):
  - -40 C to +85 C
- Non-operating temperature: -40 C to +85 C
- Operating altitude: 0 to 15,000 feet (0 to 4,572 meters)

- 5% to 95% Relative Humidity, non-condensing:
  - K-Series includes humidity sealant

## Mechanical Specification

- 6U form-factor
- Single slot, front panel width 0.8 inch (20.3mm)
- Utilizes 160-way connectors for P1 and P2
- Optional P0 connector
- IEEE 1101.10 handles
- Operating mechanical:
  - Shock - 20g, 11ms, sine
  - Vibration - 5Hz-2000Hz at 2g, 0.38mm peak displacement